

Acme®

GEIST BEAM

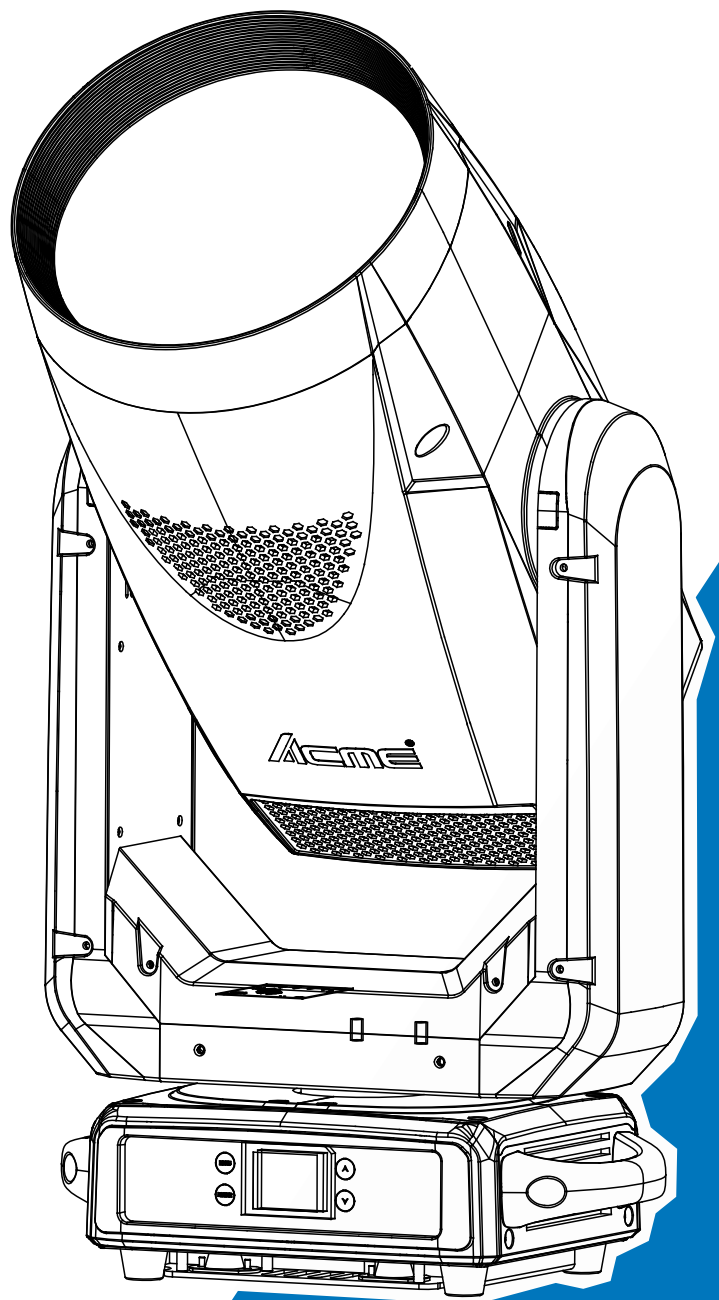

Intertek
5000057

User Manual

Please read the instruction carefully before use

CONTENTS

1. Safety Instructions	2
2. Technical Specifications	6
3. Control Panel	8
4. Effect Wheels	9
4.1 Replacing Rotating Gobos	10
5. How To Set The Unit.....	12
5.1 Main Function.....	12
5.2 Home Position Adjustment	20
6. Control By Universal DMX Controller	25
6.1 DMX512 Connection	25
6.2 Address Setting	26
6.3 DMX512 Configuration.....	26
7. Error Information	32
8. Troubleshooting	36
9. Fixture Cleaning	37

1. Safety Instructions



Please read the instruction carefully which includes important information about the installation, usage and maintenance.

WARNING

Please keep this User Guide for future consultation. If you sell the unit to another user, be sure that they also receive this instruction manual.

Important:

Damages caused by the disregard of this user manual are not subject to warranty. The dealer will not accept liability for any resulting defects or problems.

- Unpack and check carefully to ensure that there is no transportation damage before using the unit.
- This product is for indoor use only. Use only in a dry location.
- DO install and operate by qualified operator.
- DO NOT allow children to operate the fixture.
- Use safety chain when fixing the unit. Handle the unit by carrying its base instead of head only.
- The unit must be installed in a location with adequate ventilation, at least 50cm from adjacent surfaces.
- Be sure that no ventilation slots is blocked, otherwise the unit will be overheated.
- Before operation, ensure that you are connecting this product to the proper voltage in accordance with the specifications in this manual or on the product's specification label.
- It's important to ground the yellow/green conductor to earth in order to avoid electric shock.
- Minimum ambient temperature TA: 0°C. Maximum ambient temperature TA: 40°C. Do not operate this product at a lower or higher temperature.
- DO NOT connect the device to any dimmer pack.
- Keep flammable materials away from the fixture while operating to avoid fire hazard.
- Make sure the power cord is not crimped or damaged; replace it immediately if damaged.
- Unit's surface temperature may reach up to 65°C. DO NOT touch the housing bare-handed during its operation.
- Avoid any flammable liquids, water or metal from entering the unit. Once it happens, cut off the mains power immediately.

- DO NOT operate in a dirty or dusty environment. DO clean the fixture regularly.
- DO NOT touch any wire during operation as there might be a hazard of electric shock.
- Avoid entanglement of the power cord with other wires.
- The minimum distance to objects/surface must be more than 5 meters.
- Disconnect mains power before fuse replacement or servicing.
- Replace fuse only with the same type.
- In the event of serious operating problem, stop using the unit immediately.
- Never turn on and off the unit time after time.
- The housing, the lenses, or the ultraviolet filter must be replaced if they are visibly damaged.
- DO NOT open the housing as there are no user serviceable parts inside.
- DO NOT attempt to operate this unit if it becomes damaged. DO NOT attempt any repairs yourself. Repairs carried out by unskilled people can lead to damage or malfunction. Please contact the nearest authorized technical assistance center if needed.
- Disconnect this product from its power source before servicing.
- DO use the original packaging if the device is to be transported.
- Avoid direct eye exposure to the light source while the product is on.
- DO NOT operate this product if you see damage on the housing, shields, or cables. Have the damaged parts replaced by an authorized technician at once.

Installation:

The fixture should be fixed on the clamp. Always ensure that the unit is firmly fixed to avoid vibration and slipping off during operation. Ensure that the trussing or area of installation must be able to hold 10 times the weight without any deformation. Always install a safety cable that can hold at least 12 times the weight of the fixture when installing.

DO install and operate by qualified operator. It must be installed in a place where there is out of the reach of people.

1. Consignes de sécurité



Veillez lire attentivement les instructions qui contiennent des informations importantes sur l'installation, l'utilisation et l'entretien.

ATTENTION

Veillez conserver ce guide de l'utilisateur pour une consultation future. Si vous vendez l'appareil à un autre utilisateur, assurez-vous qu'il reçoive également ce manuel d'instructions.

Important:

Les dommages causés par le non-respect de ce manuel d'utilisation ne sont pas couverts par la garantie. Le revendeur n'acceptera aucune responsabilité pour les défauts ou problèmes qui en résultent.

- Déballez et vérifiez soigneusement qu'il n'y a pas de dommages dus au transport avant d'utiliser l'appareil.
- Ce produit est destiné à un usage intérieur uniquement. Il doit donc être utilisé uniquement dans un endroit sec.
- L'installation et la mise en fonctionnement doit être effectué par un opérateur qualifié.
- NE PAS permettre aux enfants d'utiliser l'appareil.
- Utilisez une chaîne de sécurité lors de la fixation de l'unité. Manipulez l'appareil en portant sa base au lieu de la tête uniquement.
- L'unité doit être installée dans un endroit avec une ventilation adéquate, à au moins 50cm des surfaces adjacentes.
- Assurez-vous qu'aucune fente d'aération du luminaire n'est obstruée, sinon il risque de surchauffer.
- Avant toute utilisation, assurez-vous que vous connectez ce luminaire à la tension appropriée conformément aux spécifications que vous trouverez dans ce manuel ou sur l'étiquette des spécifications collée sur la base du luminaire.
- Il est important de relier le file jaune/vert à la terre afin d'éviter tout choc électrique.
- Température ambiante minimale TA: 0. Température ambiante maximale TA: 40. N'utilisez pas ce luminaire à des températures inférieures ou supérieures.
- NE PAS connecter le luminaire à un pack de gradateurs.
- Gardez les matériaux inflammables à l'écart du luminaire pendant le fonctionnement pour éviter tout risque d'incendie.

- Assurez-vous que le cordon d'alimentation n'est pas pincé ou endommagé; remplacez-le immédiatement s'il est endommagé.
- La température de surface de l'unité peut atteindre 65°C. NE PAS toucher les capots à mains nues pendant son fonctionnement.
- Évitez que des liquides inflammables, de l'eau ou du métal ne pénètrent dans l'appareil. Si cela se produit, coupez immédiatement l'alimentation secteur.
- NE PAS utiliser le luminaire dans un environnement sale ou poussiéreux. Cette appareil doit être nettoyer régulièrement.
- NE touchez AUCUN file pendant le fonctionnement car il pourrait y avoir un risque de choc électrique.
- Évitez l'enchevêtrement du cordon d'alimentation avec d'autres fils.
- La distance minimale de projection sur des objets ou sur des surfaces doit être supérieure à 5 mètres.
- Débranchez l'alimentation secteur avant le remplacement ou l'entretien des fusibles.
- Remplacez le fusible uniquement par un fusible du même type.
- En cas de problème de fonctionnement grave, arrêtez immédiatement d'utiliser l'appareil.
- N'allumez et n'éteignez jamais ce luminaire à maintes reprises.
- Le boîtier, les lentilles ou le filtre ultraviolet doivent être remplacés s'ils sont visiblement endommagés.
- NE PAS ouvrir le boîtier car il ne contient aucune pièce réparable par l'utilisateur.
- NE PAS mettre ce luminaire en fonctionnement s'il est endommagé. N'effectuez pas de réparations vous-même. Les réparations ne doivent être effectuées par des personnes non qualifiées, cela peut entraîner des dommages ou des dysfonctionnements. Veuillez contacter le centre d'assistance technique agréé le plus proche si nécessaire.
- Débranchez ce produit du secteur avant de procéder à l'entretien.
- Utiliser l'emballage d'origine si l'appareil doit être transporté.
- Évitez une exposition directe des yeux à la source lumineuse lorsque le produit est allumé.
- N'utilisez PAS ce produit si vous constatez des dommages sur le boîtier, les blindages ou les câbles. Faites remplacer immédiatement les pièces endommagées par un technicien agréé.

Installation:

Le luminaire doit être fixé à l'aide de crochets. Assurez-vous toujours que l'appareil est fermement fixé pour éviter les vibrations et le glissement pendant le fonctionnement. Assurez-vous que la structure ou la zone d'installation peut supporter au moins 10 fois le poids de cet appareil sans aucune déformation. Installez toujours un câble de sécurité pouvant supporter au moins 12 fois le poids du luminaire lors de l'installation.

L'installation et l'utilisation de ce luminaire doit être effectué par un opérateur qualifié. Il doit être installé dans un endroit hors de portée des personnes.

2. Technical Specifications

Power Voltage:

100-240V~ 50/60Hz

Power Consumption:

700W

Light Source:

SUL450N-80-R00-000

Color Temperature:

7000K

Beam Angel:

3°

Movement:

Pan: 540°

Tilt: 270°

Pan/Tilt Resolution: 16-bit

Fixation: Tilt lock

Dimmer/Shutter:

Smooth dimming from 0-100%; outstanding strobe effect with variable speed

Color Wheel:

1 x color wheel with 8 fixed colors plus 1 diffuser filter and white, with rainbow effect

Gobo Wheel:

1 x static gobo wheel with 10 gobos plus open

1 x rotating gobo wheel with 7 gobos plus open

Control:

DMX Channel: 24/17 Channels

Control Mode: DMX512, RDM, Art-Net, sACN

Firmware Upgrade via DMX link or USB disk

Construction:

Display: LCD display

Date In/Out: 3-pin XLR(5-pin XLR is optional), RJ45

Power In/Out: Power Connector in/out

Protection Rating: IP20

Features:

Standard mode Ra>70

Linear CMY color mixing

Variable CTO

2 x prisms: 8-facet prism+6-facet linear prism, rotatable in both directions and overlayable

Outstanding color macro effect

Independent frost effect

Dimension/Weight:

363.8x259.6x715.4mm, 28.5kgs

14.3"x10.2"x28.2" in, 62.8lbs

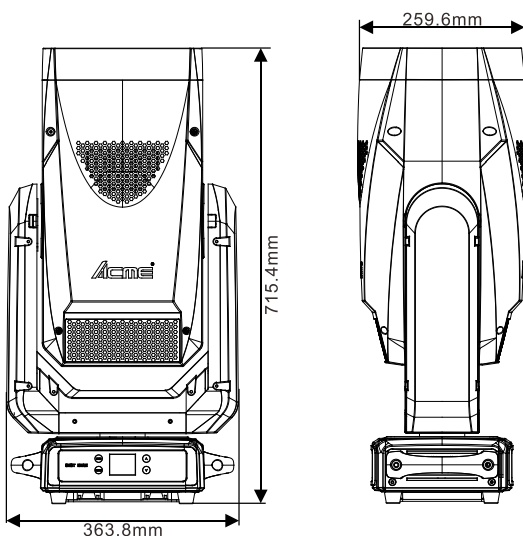

Photometric Diagram:

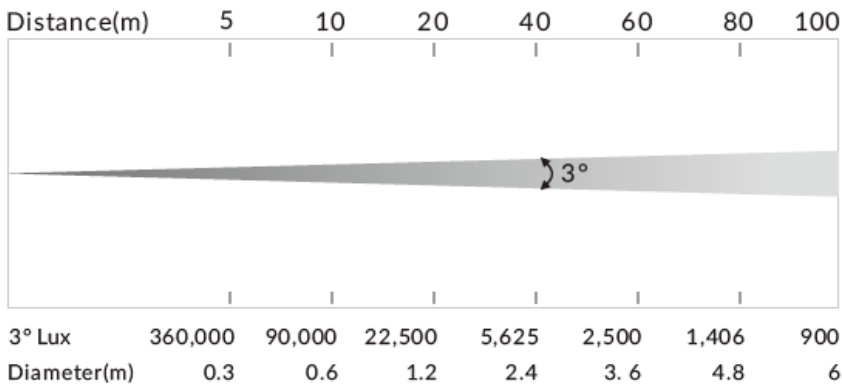

3. Control Panel

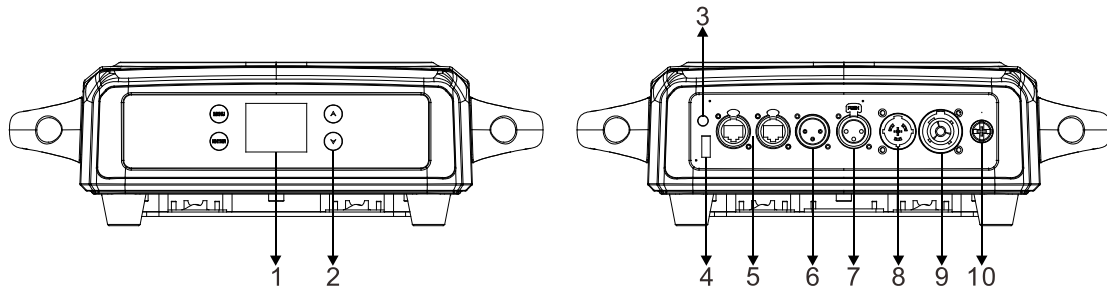

1. Display: To show the various menus and the selected function

2. Button:

MENU	To enter into move backward or leave the menu
▲ UP	To go backward to move up in the menu
▼ DOWN	To go forward to move down in the menu
ENTER	To perform the desired functions

3. BATTERY DISPLAY

4. FIRMWARE UPGRADE: Used to upgrade the fixture’s firmware

5. ETHERNET: Transfers fixture’s information to a main controller

6. DMX IN:

For DMX512 link, use 3-pin XLR cable to link the unit and DMX controller (5-pin XLR is optional)

7. DMX OUT:

For DMX512 link, use 3-pin XLR cable to link the next units (5-pin XLR is optional)

8. POWERCON IN: To connect to supply power

9. POWERCON OUT: To connect to the next fixture

10. FUSE(T 10A): Protects the unit from damage of over-voltage or short circuit

4. Effect Wheels

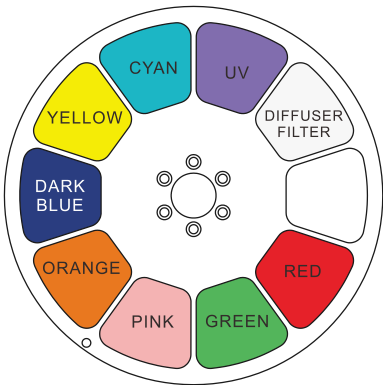

COLOR WHEEL

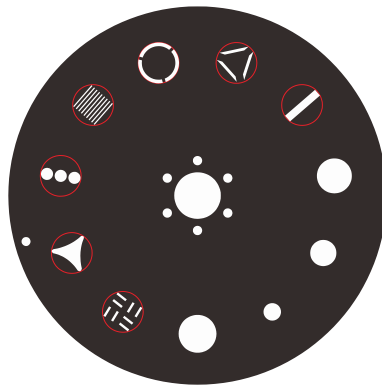

STATIC GOBO WHEEL

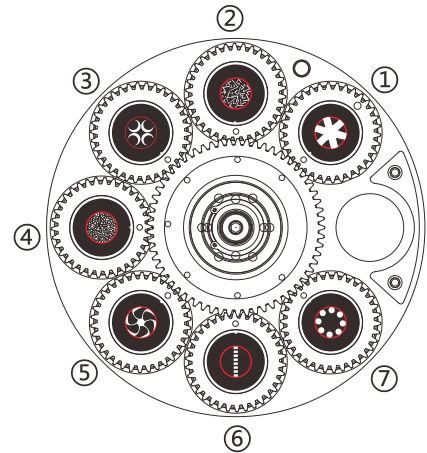

ROTATING GOBO WHEEL

DANGER!

***Install the rotating gobos with the device switched off only.
Unplug from mains before changing the rotating gobos!***

CAUTION: Never unscrew the screws of the rotating gobo as the ball bearing will otherwise be opened!

R-Gobos	Part Number
① Gobo1	3011001118
② Gobo2	3011001117
③ Gobo3	3011001114
④ Gobo4	3011001116
⑤ Gobo5	3011001115
⑥ Gobo6	3011001113
⑦ Gobo7	3011001112

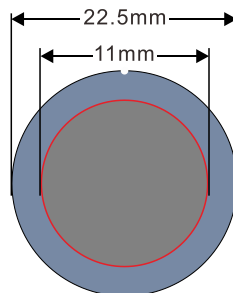

Rotating Gobos
Dimensions

4.1 Replacing Rotating Gobos

1. Unplug the power and signal adapter cables at A and unscrew the four screws at B to take out the component;

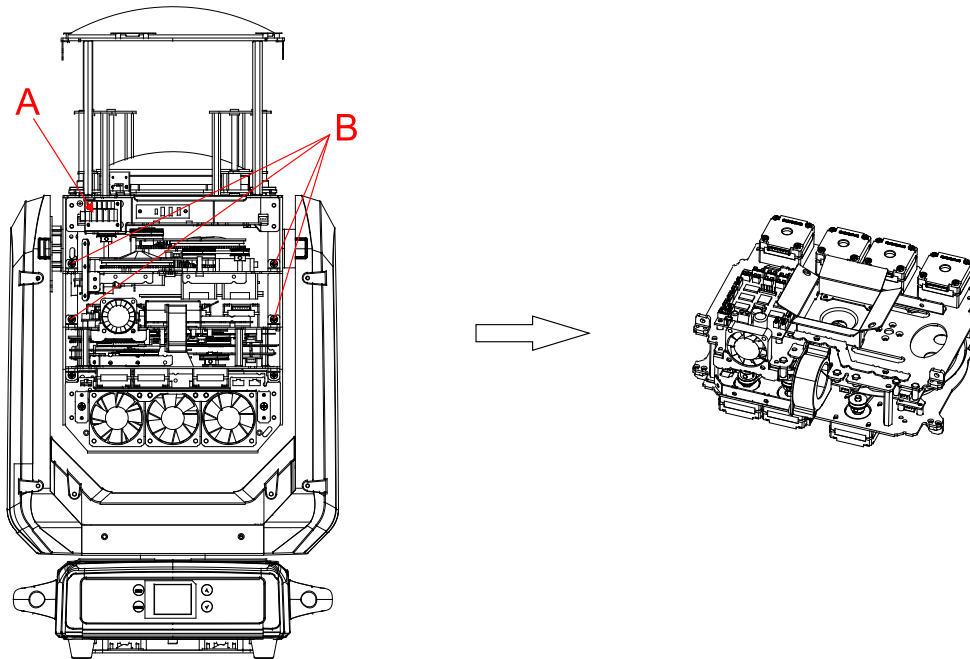

2. Unscrew the four screws at C to separate the GOBO component;

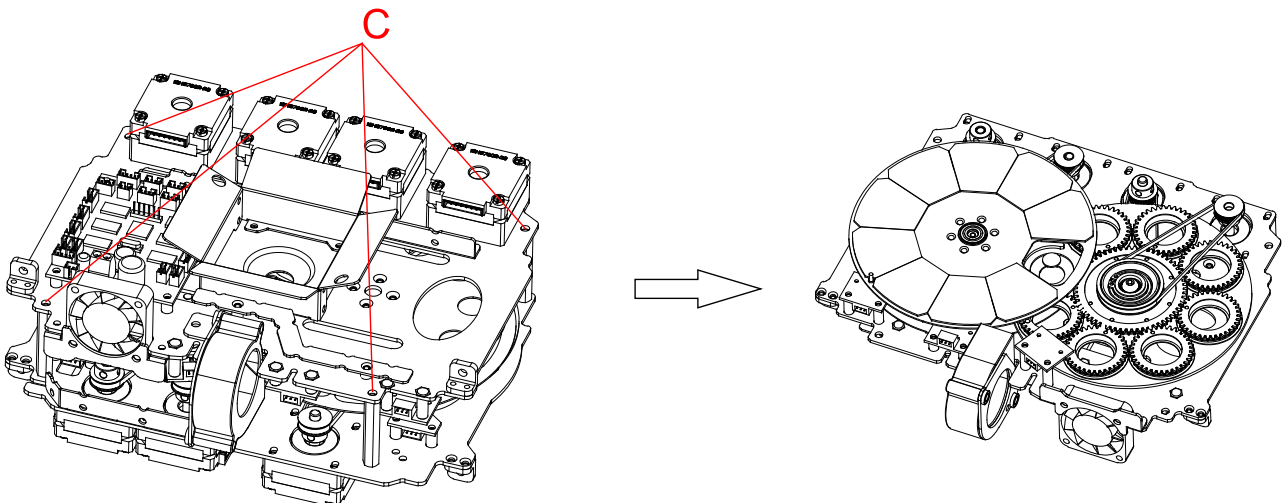

3. Half loosen the six screws at D and remove the belt; Unscrew the screw at E, then take out the rotating gobo wheel component;

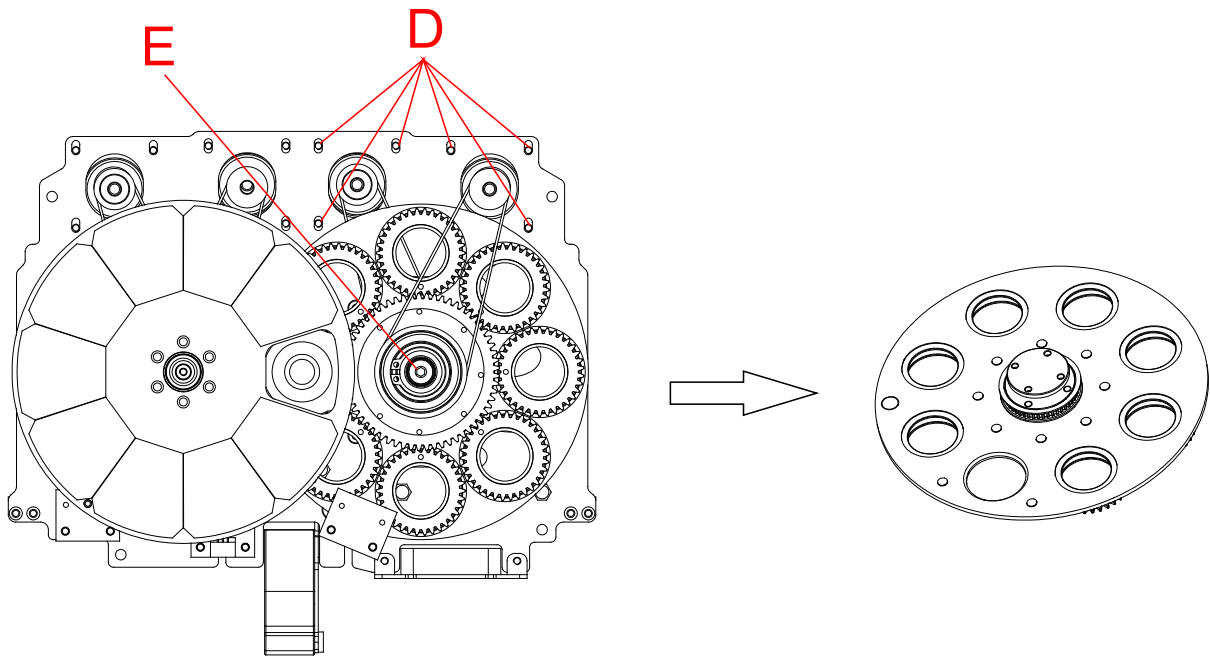

4. Press down the gobo from the edge of the rotating gobo wheel component and slowly pull it out;

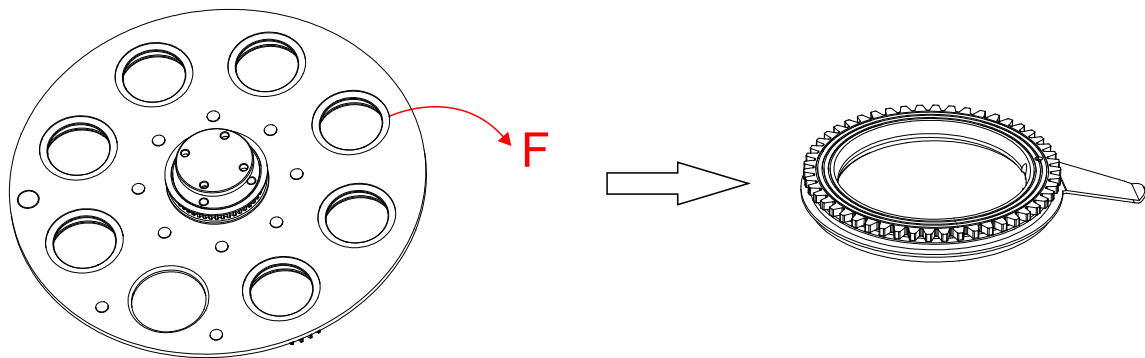

5. Remove the spring lock at G with an appropriate tool like tweezers (if the gobo is coated with glass glue, do remove it with some good glass cleaning fluid before removing the spring lock to avoid damage to the gobo).

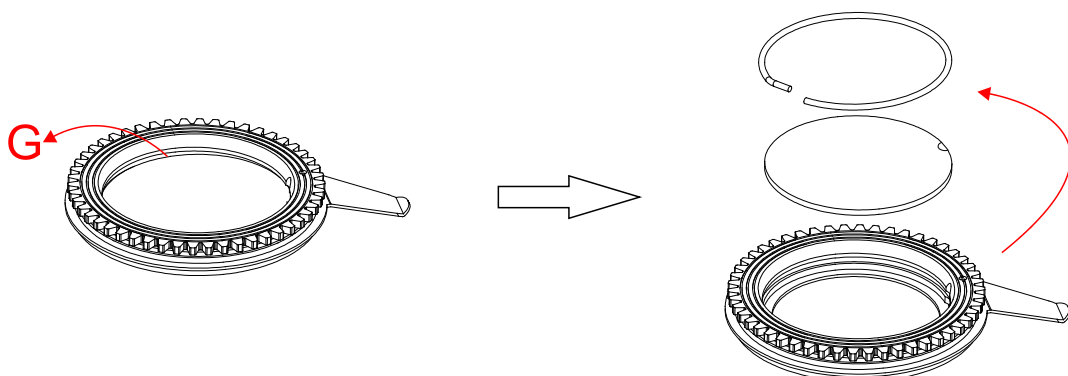

6. Do not touch the surface of the gobo with bare fingers. The gobo has a small position point at its edge which has to aim at the position point on the gobo holder like H shows (glossy side towards the light source).

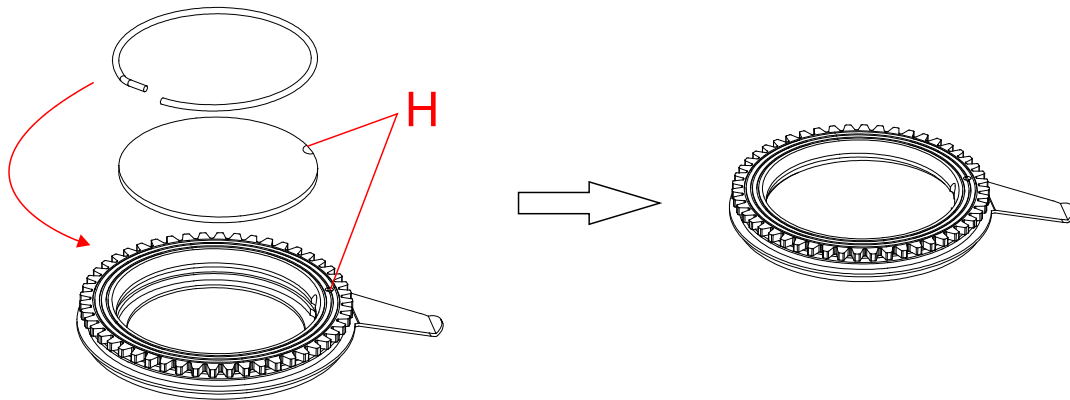

7. Insert the gobo holder back into the rotating gobo wheel component in this way that its position point has to exactly aim at the center of the rotating gobo wheel.

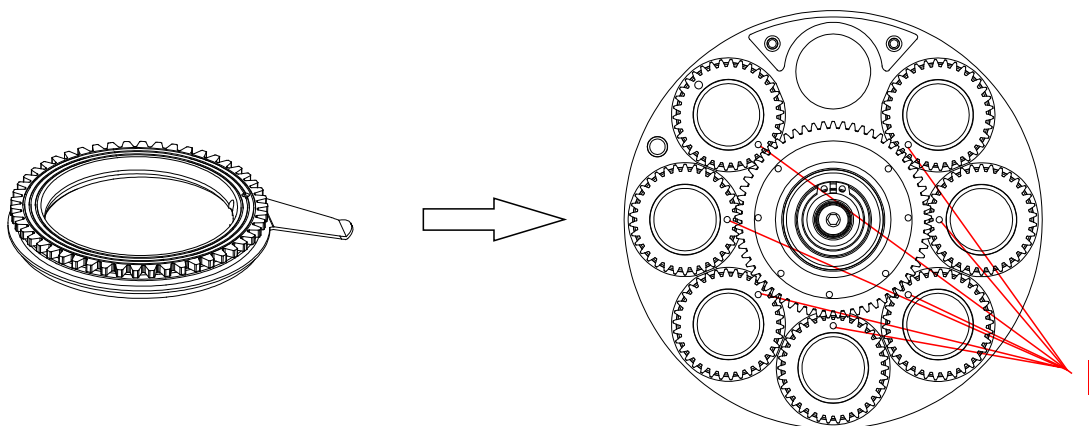

8. After installation, put the component back to the fixture.

5. How To Set The Unit

5.1 Main Function

Turn on the unit, press the MENU button into menu mode, and press the UP/DOWN button until the required function is shown on the monitor. Select the function by pressing the ENTER button. Use the UP/DOWN button to choose the submenu, press the ENTER button to store and automatically return to the last menu. Press the MENU button or let the unit idle 30 seconds to exit menu mode.

The main functions are shown below:

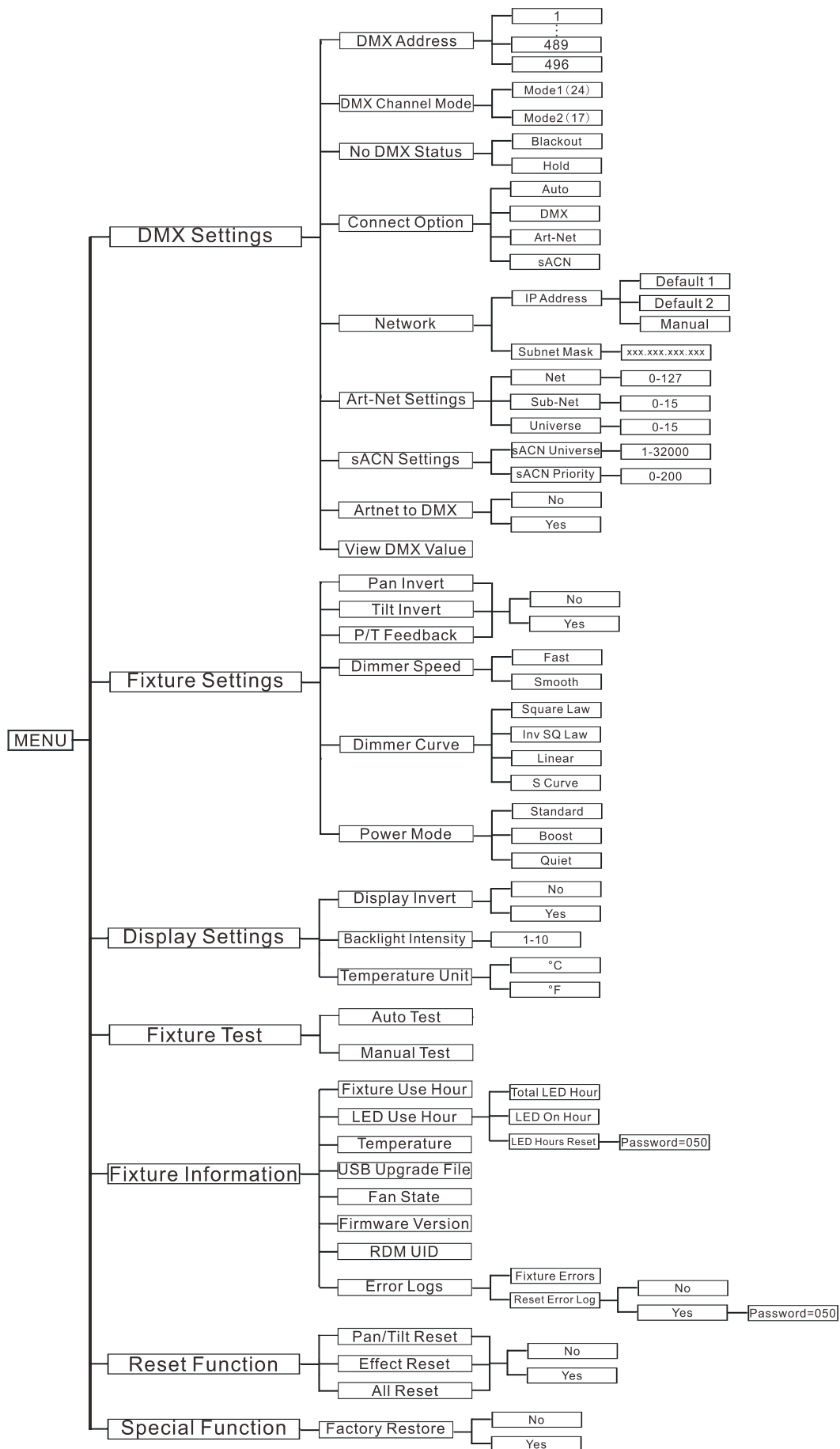

DMX Settings

To select **DMX Settings**, press the **ENTER** button to confirm, use the **UP/DOWN** button to select **DMX Address**, **DMX Channel Mode**, **No DMX Status**, **Connect Option**, **Network**, **Art-Net Settings**, **sACN Settings**, **Artnet to DMX** or **View DMX Value**.

DMX Address

To select **DMX Address**, press the **ENTER** button to confirm. Use the **UP/DOWN** button to adjust the address from **001** to **489/496**, press the **ENTER** button to store. Press the **MENU** button back to the last menu or let the unit idle 30 seconds to exit menu mode.

DMX Channel Mode

To select **DMX Channel Mode**, press the **ENTER** button to confirm. Use the **UP/DOWN** button to select **Mode1(24)** or **Mode2(17)**, press the **ENTER** button to store. Press the **MENU** button back to the last menu or let the unit idle 30 seconds to exit menu mode.

No DMX Status

To select **No DMX Status**, press the **ENTER** button to confirm. Use the **UP/DOWN** button to select **Blackout**(fixture blacks out if DMX signal stops) or **Hold**(fixture continues to obey the last command it received Via DMX if DMX signal stops), press the **ENTER** button to store. Press the **MENU** button back to the last menu or let the unit idle 30 seconds to exit menu mode.

Connect Option

To select **Connect Option**, press the **ENTER** button to confirm. Use the **UP/DOWN** button to select **Auto**, **DMX**, **Art-Net** or **sACN**, press the **ENTER** button to store. Press the **MENU** button back to the last menu or let the unit idle 30 seconds to exit menu mode.

Network

To select **Network**, press the **ENTER** button to confirm. Use the **UP/DOWN** button to select **IP Address** or **Subnet Mask**, press the **ENTER** button to store. Press the **MENU** button back to the last menu or let the unit idle 30 seconds to exit menu mode.

Art-Net Settings

To select **Art-Net Settings**, press the **ENTER** button to confirm. Use the **UP/DOWN** button to select **Net**, **Subnet** or **Universe**, press the **ENTER** button to store. Press the **MENU** button back to the last menu or let the unit idle 30 seconds to exit menu mode.

sACN Settings

To select **sACN Settings**, press the **ENTER** button to confirm. Use the **UP/DOWN** button to select **sACN Universe** or **sACN Priority**, press the **ENTER** button to store. Press the **MENU** button back to the last menu or let the unit idle 30 seconds to exit menu mode.

Artnet to DMX

To select **Artnet to DMX**, press the **ENTER** button to confirm. Use the **UP/DOWN** button to select **No** or **Yes**, press the **ENTER** button to store. Press the **MENU** button back to the last menu or let the unit idle 30 seconds to exit menu mode.

View DMX Value

To select **View DMX Value**, press the **ENTER** button to confirm. Use the **UP/DOWN** button to view the DMX channel value. Press the **MENU** button back to the last menu or let the unit idle 30 seconds to exit menu mode.

Fixture Settings

To select **Fixture Settings**, press the **ENTER** button to confirm, use the **UP/DOWN** button to select **Pan Invert, Tilt Invert, P/T Feedback, Dimmer Speed, Dimmer Curve** or **Power Mode**.

Pan Invert

To select **Pan Invert**, press the **ENTER** button to confirm. Use the **UP/DOWN** button to select **No** (normal) or **Yes** (pan invert), press the **ENTER** button to store. Press the **MENU** button back to the last menu or let the unit idle 30 seconds to exit menu mode.

Tilt Invert

To select **Tilt Invert**, press the **ENTER** button to confirm. Use the **UP/DOWN** button to select **No** (normal) or **Yes** (tilt invert), press the **ENTER** button to store. Press the **MENU** button back to the last menu or let the unit idle 30 seconds to exit menu mode.

P/T Feedback

To select **P/T Feedback**, press the **ENTER** button to confirm. Use the **UP/DOWN** button to select **No** (Pan or tilt's position will not feedback while out of step) or **Yes** (Feedback while pan/tilt out of step), press the **ENTER** button to store. Press the **MENU** button back to the last menu or let the unit idle 30 seconds to exit menu mode.

Dimmer Speed

To select **Dimmer Speed**, press the **ENTER** button to confirm. Use the **UP/DOWN** button to select **Fast** or **Smooth**, press the **ENTER** button to store. Press the **MENU** button back to the last menu or let the unit idle 30 seconds to exit menu mode.

Dimmer Curve

To select **Dimmer Curve**, press the **ENTER** button to confirm. Use the **DOWN/UP** button to select **Square Law**, **Inv SQ Law**, **Linear** or **S Curve**, press the **ENTER** button to store. Press the **MENU** button back to the last menu or let the unit idle 30 seconds to exit menu mode.

Dimmer Modes

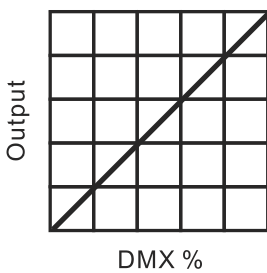

Optically Linear

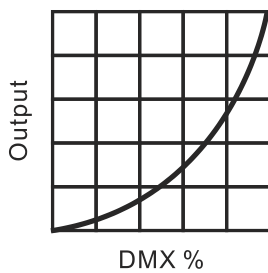

Square Law

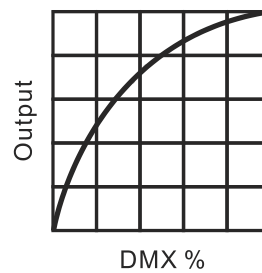

Inverse Square Law

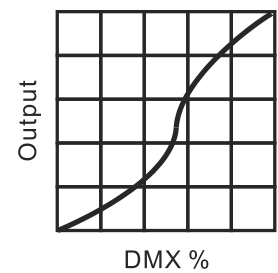

S-curve

Optically Linear: The increase in light intensity appears to be linear as DMX value is increased.

Square Law: Light intensity control is finer at low levels and coarser at high levels.

Inverse Square Law: Light intensity control is coarser at low levels and finer at high levels.

S-Curve: Light intensity control is finer at low levels and high levels and coarser at medium levels.

Power Mode

To select **Power Mode**, press the **ENTER** button to confirm. Use the **UP/DOWN** button to select **Standard**, **Boost** or **Quiet**, press the **ENTER** button to store. Press the **MENU** button back to the last menu or let the unit idle 30 seconds to exit menu mode.

Display Settings

To select **Display Settings**, press the **ENTER** button to confirm, use the **UP/DOWN** button to select **Display Invert**, **Backlight Intensity**, **Temperature Unit** or **Language**.

Display Invert

Select **Display Invert**, press the **ENTER** button to confirm. Use the **UP/DOWN** button to select **No** (normal display) or **Yes** (invert display), press the **ENTER** button to store. Press the **MENU** button back to the last menu or let the unit idle 30 seconds to exit menu mode.

Backlight Intensity

Select **Backlight Intensity**, press the **ENTER** button to confirm. Use the **UP/DOWN** button to adjust backlight intensity from **1** (dark) to **10** (bright), press the **ENTER** button to store. Press the **MENU** button back to the last menu or let the unit idle 30 seconds to exit menu mode.

Temperature Unit

Select **Temperature Unit**, press the **ENTER** button to confirm. Use the **UP/DOWN** button to select **°C** or **°F**, press the **ENTER** button to store. Press the **MENU** button back to the last menu or let the unit idle 30 seconds to exit menu mode.

Fixture Test

To select **Fixture Test**, press the **ENTER** button to confirm, use the **UP/DOWN** button to select **Auto Test** or **Manual Test**

Auto Test

Select **Auto Test**, press the **ENTER** button to confirm, the unit will run built-in programs to automatically test its functions. Press the **MENU** button back to the last menu or exit menu mode after auto test.

Manual Test

Select **Manual Test**, press the **ENTER** button to confirm, the present channel will show on the display, use the **UP/DOWN** button to select channel, press the **ENTER** button to confirm, then use the **UP/DOWN** button to adjust the value, press the **ENTER** button to store, the fixture will run as the channel value indicates. Press the **MENU** button back to the last menu or exit menu mode idling 30 seconds.

(All channels value will become 0 after exiting Manual Test menu)

Fixture Information

To select **Fixture Information**, press the **ENTER** button to confirm, use the **UP/DOWN** button to select **Fixture Use Hour**, **LED Use Hour**, **Temperature**, **USB Upgrade File**, **Fan State**, **Firmware Version**, **RDM UID** or **Error Logs**.

Fixture Use Hour

Select **Fixture Use Hour**, press the **ENTER** button to confirm, fixture use hour will show on the display, press the **MENU** button to exit.

LED Use Hour

To select **LED Use Hour**, press the **ENTER** button to confirm, use the **UP/DOWN** button to select **Total LED Hour**, **LED On Hour** or **LED Hours Reset**, press the **ENTER** button to store. Use the **UP/DOWN** button to select **LED Hours Reset**, press the **ENTER** button to confirm, use the **UP/DOWN** button to set the password **050** to reset the LED hours, press the **ENTER** button to store. Press the **MENU** button back to the last menu or exit menu mode let the unit idle 30 seconds.

Temperature

Select **Temperature**, press the **ENTER** button to confirm, fixture temperature will show on the display, press the **MENU** button to exit.

USB Upgrade File

Select **USB Upgrade File**, press the **ENTER** button to confirm, USB upgrade file will show on the display, press the **MENU** button back to exit.

Fan State

Select **Fan State**, press the **ENTER** button to confirm, fan state will show on the display, press the **MENU** button to exit.

Firmware Version

Select **Firmware Version**, press the **ENTER** button to confirm, firmware version will show on the display, press the **MENU** button back to exit.

RDM UID

Select **RDM UID**, press the **ENTER** button to confirm, RDM UID will show on the display, press the **MENU** button back to exit.

Error Logs

Select **Error Logs**, press the **ENTER** button to confirm. Use the **UP/DOWN** button to select **Fixture Errors** or **Reset Error Log**, press the **ENTER** button to store. Select **Reset Error Log**, press the **ENTER** button to confirm. Use the **UP/DOWN** button to select **No** or **Yes**, press the **ENTER** button to store. Select **Yes**, press the **ENTER** button to confirm. Use the **UP/DOWN** button to set the password **050**, press the **ENTER** button to store. Press the **MENU** button back to the last menu or let the unit idle 30 seconds to exit menu mode.

Reset Function

To select **Reset Function**, press the **ENTER** button to confirm, use the **UP/DOWN** button to select **Pan/Tilt Reset**, **Effect Reset** or **All Reset**.

Pan/Tilt Reset

Select **Pan/Tilt Reset**, press the **ENTER** button to confirm, use the **UP/DOWN** button to select **No**(normal) or **Yes** (the unit will run built-in program to reset pan and tilt to their home positions), press **ENTER** button to store. Press the **MENU** button to exit.

Effect Reset

Select **Effect Reset**, press the **ENTER** button to confirm, use the **UP/DOWN** button to select **No**(normal) or **Yes** (the unit will run built-in program to reset effect to their home positions), press **ENTER** button to store. Press the **MENU** button to exit.

All Reset

Select **All Reset**, press the **ENTER** button to confirm, use the **UP/DOWN** button to select **No**(normal) or **Yes** (the unit will run built-in program to reset all motors to their home positions), press **ENTER** button to store. Press the **MENU** button to exit.

Special Function

Factory Restore

Select **Factory Restore**, press the **ENTER** button to confirm, use the **UP/DOWN** button to select **No**(normal) or **Yes** (the fixture will reset to factory settings), press **ENTER** button to store. Press the **MENU** button to exit.

RDM FUNCTIONS

Select the MANUFACTURER menu to display the manufacturer of the fixture.

Select the SOFTWARE VERSION menu and the program version number of the fixture will be displayed.

Select the DMX START ADDRESS menu to change the DMX 512 address (001-512).

Select the DEVICE MODEL DESCRIPTION menu to display the model of the fixture.

Select the DEVICE LABEL menu to change the model of the fixture.

Select the DMX PERSONALITY menu to set the channel mode of the fixture (24/17 channel).

Select the DMX PERSONALITY DESCRIPTION menu to display the current channel mode of the fixture.

Select the DEVICE HOURS menu to display the running time of the fixture.

Select the PAN INVERT menu and the fixture will run the pan invert mode.

Select the TILT INVERT menu and the fixture will run the tilt invert mode.

Select the RESET DEVICE menu, the WARM RESET/COLD RESET option will be displayed. When WARM RESET is selected, the fixture will start a warm reset, and exit when COLD RESET is selected.

5.2 Home Position Adjustment

Press the MENU button into menu mode, then press the ENTER button for about 3 seconds into offset mode to adjust the home position. Select the function by pressing the ENTER button. Use the UP/DOWN button to choose the submenu, press the ENTER button to store and automatically return to the last menu. Press MENU button to exit.

Offset Menu	Dimming Start	0-9999
	Frequency(Hz)	1072-1327
	Dimming Start1	-128-127
	Dimming Start2	-128-127
	Dimming Start3	-128-127
	Dimming Start4	-128-127
	Pan	-128-127
	Tilt	-128-127
	Cyan	-128-127
	Magenta	-128-127
	Yellow	-128-127
	Cto	-128-127
	Color	-128-127
	Gobo	-128-127
	R-Gobo1	-128-127
	Gobo2	-128-127
	Prism1	-128-127
	R-Prism1	-128-127
	Prism2	-128-127
	R-Prism2	-128-127
Frost	0-255	
Focus	-128-127	

Dimming Start

Enter offset mode, Select **Dimming Start**, press the **ENTER** button to confirm, the present position will blink on the display, use the **UP/DOWN** button to offset the value from 0 to 9999, press the **ENTER** button to store. Press the **MENU** button to exit.

Frequency(Hz)

Enter offset mode, Select **Frequency(Hz)**, press the **ENTER** button to confirm, the present position will blink on the display, use the **UP/DOWN** button to offset the value from 1072 to 1327, press the **ENTER** button to store. Press the **MENU** button to exit.

Dimming Start1

Enter offset mode, Select **Dimming Start1**, press the **ENTER** button to confirm, the present position will blink on the display, use the **UP/DOWN** button to offset the value from -128 to 127, press the **ENTER** button to store. Press the **MENU** button to exit.

Dimming Start2

Enter offset mode, Select **Dimming Start2**, press the **ENTER** button to confirm, the present position will blink on the display, use the **UP/DOWN** button to offset the value from -128 to 127, press the **ENTER** button to store. Press the **MENU** button to exit.

Dimming Start3

Enter offset mode, Select **Dimming Start3**, press the **ENTER** button to confirm, the present position will blink on the display, use the **UP/DOWN** button to offset the value from -128 to 127, press the **ENTER** button to store. Press the **MENU** button to exit.

Dimming Start4

Enter offset mode, Select **Dimming Start4**, press the **ENTER** button to confirm, the present position will blink on the display, use the **UP/DOWN** button to offset the value from -128 to 127, press the **ENTER** button to store. Press the **MENU** button to exit.

Pan

Enter offset mode, Select **Pan**, press the **ENTER** button to confirm, the present position will blink on the display, use the **UP/DOWN** button to offset the value from -128 to 127, press the **ENTER** button to store. Press the **MENU** button to exit.

Tilt

Enter offset mode, Select **Tilt**, press the **ENTER** button to confirm, the present position will blink on the display, use the **UP/DOWN** button to offset the value from -128 to 127, press the **ENTER** button to store. Press the **MENU** button to exit.

Cyan

Enter offset mode, Select **Cyan**, press the **ENTER** button to confirm, the present position will blink on the display, use the **UP/DOWN** button to offset the value from -128 to 127, press the **ENTER** button to store. Press the **MENU** button to exit.

Magenta

Enter offset mode, Select **Magenta**, press the **ENTER** button to confirm, the present position will blink on the display, use the **UP/DOWN** button to offset the value from -128 to 127, press the **ENTER** button to store. Press the **MENU** button to exit.

Yellow

Enter offset mode, Select **Yellow**, press the **ENTER** button to confirm, the present position will blink on the display, use the **UP/DOWN** button to offset the value from -128 to 127, press the **ENTER** button to store. Press the **MENU** button to exit.

Cto

Enter offset mode, Select **Cto**, press the **ENTER** button to confirm, the present position will blink on the display, use the **UP/DOWN** button to offset the value from -128 to 127, press the **ENTER** button to store. Press the **MENU** button to exit.

Color

Enter offset mode, Select **Color**, press the **ENTER** button to confirm, the present position will blink on the display, use the **UP/DOWN** button to offset the value from -128 to 127, press the **ENTER** button to store. Press the **MENU** button to exit.

Gobo

Enter offset mode, Select **Gobo**, press the **ENTER** button to confirm, the present position will blink on the display, use the **UP/DOWN** button to offset the value from -128 to 127, press the **ENTER** button to store. Press the **MENU** button to exit.

R-Gobo1

Enter offset mode, Select **R-Gobo1**, press the **ENTER** button to confirm, the present position will blink on the display, use the **UP/DOWN** button to offset the value from -128 to 127, press the **ENTER** button to store. Press the **MENU** button to exit.

Gobo2

Enter offset mode, Select **Gobo2**, press the **ENTER** button to confirm, the present position will blink on the display, use the **UP/DOWN** button to offset the value from -128 to 127, press the **ENTER** button to store. Press the **MENU** button to exit.

Prism1

Enter offset mode, Select **Prism1**, press the **ENTER** button to confirm, the present position will blink on the display, use the **UP/DOWN** button to offset the value from -128 to 127, press the **ENTER** button to store. Press the **MENU** button to exit.

R-Prism1

Enter offset mode, Select **R-Prism1**, press the **ENTER** button to confirm, the present position will blink on the display, use the **UP/DOWN** button to offset the value from -128 to 127, press the **ENTER** button to store. Press the **MENU** button to exit.

Prism2

Enter offset mode, Select **Prism2**, press the **ENTER** button to confirm, the present position will blink on the display, use the **UP/DOWN** button to offset the value from -128 to 127, press the **ENTER** button to store. Press the **MENU** button to exit.

R-Prism2

Enter offset mode, Select **R-Prism2**, press the **ENTER** button to confirm, the present position will blink on the display, use the **UP/DOWN** button to offset the value from -128 to 127, press the **ENTER** button to store. Press the **MENU** button to exit.

Frost

Enter offset mode, Select **Frost**, press the **ENTER** button to confirm, the present position will blink on the display, use the **UP/DOWN** button to offset the value from 0 to 255, press the **ENTER** button to store. Press the **MENU** button to exit.

Focus

Enter offset mode, Select **Focus**, press the **ENTER** button to confirm, the present position will blink on the display, use the **UP/DOWN** button to offset the value from -128 to 127, press the **ENTER** button to store. Press the **MENU** button to exit.

6. Control By Universal DMX Controller

6.1 DMX512 Connection

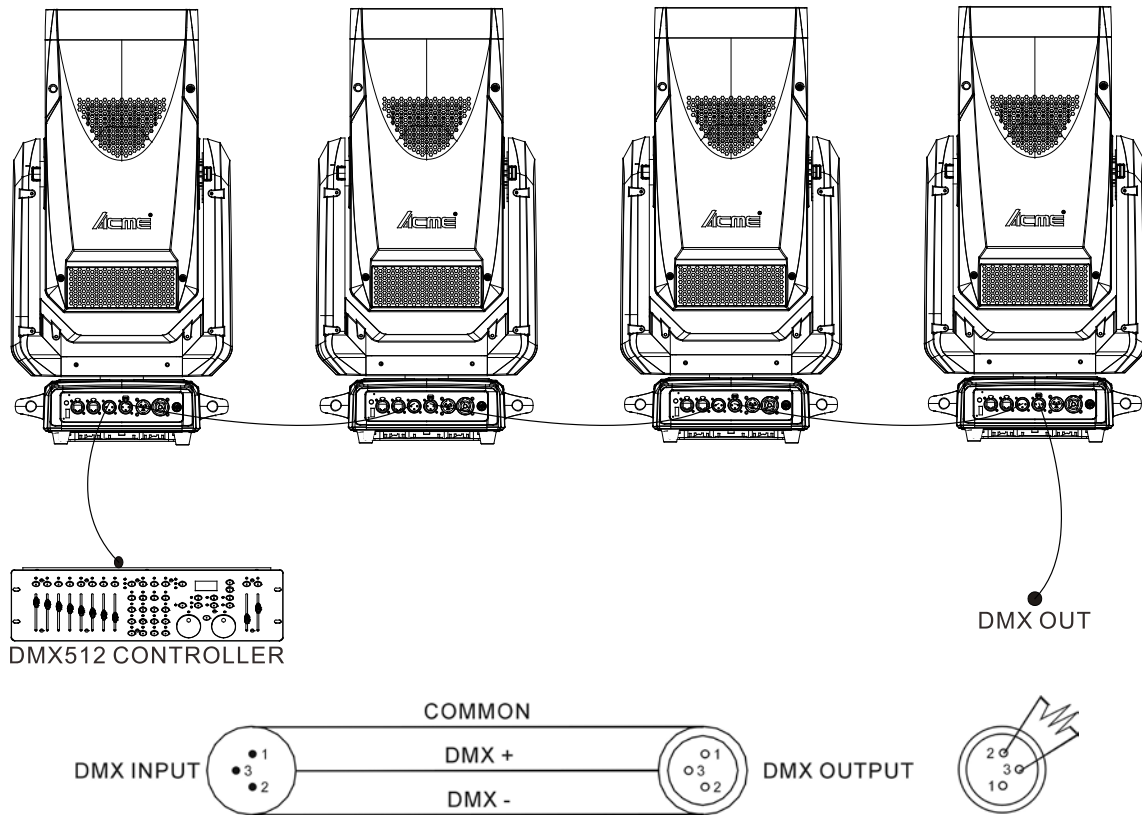

1. At last unit, the DMX cable has to be terminated with a terminator. Solder a 120-ohm 1/4W resistor between pin 2(DMX-) and pin 3(DMX+) into a 3-pin XLR-plug and plug it in the DMX-output of the last unit.
2. Connect the unit together in a “daisy chain” by XLR plug cable from the output of the unit to the input of the next unit. The cable can only be used in series and cannot be connected in parallel. DMX 512 is a very high-speed signal. Inadequate or damaged cables, soldered joints or corroded connectors can easily distort the signal and shut down the system.
3. The DMX output and input connectors are pass-through to maintain the DMX circuit, when one of the units’ power is disconnected.
4. Each lighting unit needs to have a DMX address to receive the data by the controller. The address number is between 1-512.
5. The end of the DMX 512 system should be terminated to reduce signal errors.
6. 3 pin XLR connectors are more popular than 5 pins XLR.
3 pin XLR: Pin 1: GND, Pin 2: Negative signal (-), Pin 3: Positive signal (+)
5 pin XLR: Pin 1: GND, Pin 2: Negative signal (-), Pin 3: Positive signal (+), Pin4, Pin5 not used.

6.2 Address Setting

If you use a universal DMX controller to control the units, you have to set DMX address from 1 to 512 so that the units can receive DMX signal.

Press the MENU button to enter menu mode, select DMX Settings, press the ENTER button to confirm, use the UP/DOWN button to select DMX Address, press the ENTER button to confirm, the present address will blink in the display, use the UP/DOWN button to adjust the address from 001 to 512, press the ENTER button to store. Press the MENU button back to the last menu or let the unit idle 30 seconds to exit menu mode.

Please refer to the following diagram to address your DMX512 channel for the first 4 units.

Channel mode	Unit 1 Address	Unit 2 Address	Unit 3 Address	Unit 4 Address
24 channels	1	25	49	73
17 channels	1	18	35	52

6.3 DMX512 Configuration

Please control the fixture by referring to the configurations below

Attentions:

1. The unit will maintain the last condition until reset if you cut-off the DMX signal.
2. For the channel Function, keep the value for about 3 seconds, then the corresponding function will take into effect.

24 Channels (Mode 1):

CHANNEL	VALUE	FUNCTION
1	000-255	PAN 0°→540°
2	000-255	PAN FINE
3	000-255	TILT 0°→270°
4	000-255	TILT FINE
5	000-255	PAN/TILT SPEED Fast to Slow
6	000-255	CYAN 0%→100%

7	000-255	MAGENTA 0%→100%
8	000-255	YELLOW 0%→100%
9	000-255	CTO 7000K→2700K
10	000-007 008-011 012-015 016-019 020-023 024-027 028-031 032-035 036-039 040-127 128-189 190-193 194-255	COLOR Open Color 1 Color 2 Color 3 Color 4 Color 5 Color 6 Color 7 Color 8 Color Index Rotation Fast to Slow Stop Rotation Slow to Fast
11	000-007 008-015 016-023 024-031 032-039 040-047 048-055 056-063 064-071 072-079 080-087 088-095 096-103 104-111 112-127 128-189 190-193 194-255	GOBO1 Open Gobo 1 Gobo 2 Gobo 3 Gobo 4 Gobo 5 Gobo 6 Gobo 7 Gobo 1 Shaking Slow to Fast Gobo 2 Shaking Slow to Fast Gobo 3 Shaking Slow to Fast Gobo 4 Shaking Slow to Fast Gobo 5 Shaking Slow to Fast Gobo 6 Shaking Slow to Fast Gobo 7 Shaking Slow to Fast Clockwise Rotation Fast to Slow Stop Counter-Clockwise Rotation Slow to Fast
12	000-127 128-189 190-193 194-255	R-GOBO1 Index 0°→360° Clockwise Rotation Fast to Slow Stop Counter-Clockwise Rotation Slow to Fast
13	000-007	GOBO2 Open

	008-013 014-019 020-025 026-031 032-037 038-043 044-049 050-055 056-061 062-067 068-073 074-079 080-085 086-091 092-097 098-103 104-109 110-115 116-121 122-127 128-189 190-193 194-255	Gobo 1 Gobo 2 Gobo 3 Gobo 4 Gobo 5 Gobo 6 Gobo 7 Gobo 8 Gobo 9 Gobo 10 Gobo 1 Shaking Slow to Fast Gobo 2 Shaking Slow to Fast Gobo 3 Shaking Slow to Fast Gobo 4 Shaking Slow to Fast Gobo 5 Shaking Slow to Fast Gobo 6 Shaking Slow to Fast Gobo 7 Shaking Slow to Fast Gobo 8 Shaking Slow to Fast Gobo 9 Shaking Slow to Fast Gobo 10 Shaking Slow to Fast Clockwise Rotation Fast to Slow Stop Counter-Clockwise Rotation Slow to Fast
14	000-007 008-255	PRISM1 No Effect On
15	000-127 128-189 190-193 194-255	R-PRISM1 Index 0°→360° Clockwise Rotation Fast to Slow Stop Counter-Clockwise Rotation Slow to Fast
16	000-007 008-255	PRISM2 No Effect On
17	000-127 128-189 190-193 194-255	R-PRISM2 Index 0°→360° Clockwise Rotation Fast to Slow Stop Counter-Clockwise Rotation Slow to Fast
18	000-255	FROST 0%→100%
19	000-007 008-015 016-131 132-139	STROBE Close Open Strobe from Slow to Fast Open

	140-181 182-189 190-231 232-239 240-247 248-255	Fast Open Slow Close Open Fast Close Slow Open Open Random Strobe Open
20	000-255	DIMMER 0%→100%
21	000-255	DIMMER FINE
22	000-255	FOCUS 0%→100%
23	000-255	FOCUS FINE
24	000-029 030-039 040-049 050-059 060-069 070-079 080-089 090-099 100-109 110-119 120-129 130-139 140-179 180-189 190-199 200-209 210-219 220-229 230-255	SPECIAL FUNCTION Null Dimmer Curve Linear Dimmer Curve Square Law Dimmer Curve Inv Square Law Dimmer Curve S Power Mode Standard Power Mode Boost Power Mode Quiet Led Frequency Setting Enable Led Frequency Setting Disable Soften Enable Soften Disable Null Dimmer Speed Fast Dimmer Speed Smooth Reset All Reset Effect Reset Pan/Tilt Null

17 Channels (Mode 2):

CHANNEL	VALUE	FUNCTION
1	000-255	PAN 0°→540°
2	000-255	PAN FINE
3	000-255	TILT 0°→270°
4	000-255	TILT FINE
5	000-255	PAN/TILT SPEED Fast to Slow
6	000-255	CYAN 0%→100%
7	000-255	MAGENTA 0%→100%
8	000-255	YELLOW 0%→100%
9	000-255	CTO 7000K→2700K
10	000-007 008-011 012-015 016-019 020-023 024-027 028-031 032-035 036-039 040-127 128-189 190-193 194-255	COLOR Open Color 1 Color 2 Color 3 Color 4 Color 5 Color 6 Color 7 Color 8 Color Index Rotation Fast to Slow Stop Rotation Slow to Fast
11	000-255	FROST 0%→100%
12	000-007 008-015 016-131 132-139 140-181 182-189 190-231 232-239	STROBE Close Open Strobe from Slow to Fast Open Fast Open Slow Close Open Fast Close Slow Open Open

	240-247 248-255	Random Strobe Open
13	000-255	DIMMER 0%→100%
14	000-255	DIMMER FINE
15	000-255	FOCUS 0%→100%
16	000-255	FOCUS FINE
17	000-029 030-039 040-049 050-059 060-069 070-079 080-089 090-099 100-109 110-119 120-129 130-139 140-179 180-189 190-199 200-209 210-219 220-229 230-255	SPECIAL FUNCTION Null Dimmer Curve Linear Dimmer Curve Square Law Dimmer Curve Inv Square Law Dimmer Curve S Power Mode Standard Power Mode Boost Power Mode Quiet Led Frequency Setting Enable Led Frequency Setting Disable Soften Enable Soften Disable Null Dimmer Speed Fast Dimmer Speed Smooth Reset All Reset Effect Reset Pan/Tilt Null

7. Error Information

Error codes are shown continuously in the display when the fixture fails and they will not disappear until the fixture is repaired.

1. CPU-B/C/D/E/F Error

Check whether the 485 (DATA) leads on the PCB board are installed in place or disconnected.

Check whether the related 485 (DATA) signal circuit on the PCB board is damaged.

2. Pan Reset Error

Check whether the position of the pan where the magnet is installed falls off or is damaged.

Check whether there are obstacles in the pan operating range.

Check whether the Hall element on the pan is damaged.

Check whether the lead connecting the Hall element on the pan and the PCB board is in poor contact or disconnected.

Check whether the motor on the pan is damaged.

Check whether the related circuit of the motor drive board on the pan is damage.

3. Pan Encode Error

Check whether the encoder on the pan is damaged.

Check whether the lead connecting the encoder on the pan and the PCB board is in poor contact or disconnected.

4. Tilt Reset Error

Check whether the position of the tilt where the magnet is installed falls off or is damaged.

Check whether there are obstacles in the tilt operating range.

Check whether the Hall element on the tilt is damaged.

Check whether the lead connecting the Hall element on the tilt and the PCB board is in poor contact or disconnected.

Check whether the motor on the tilt is damaged.

Check whether the related circuit of the motor drive board on the tilt is damage.

5. Tilt Encode Error

Check whether the encoder on the tilt is damaged.

Check whether the lead connecting the encoder on the tilt and the PCB board is in poor contact or disconnected.

6. Color Reset Error

Check whether the position of the color wheel where the magnet is installed falls off or is damaged.

Check whether there are obstacles in the color wheel operating range.

Check whether the Hall element on the color wheel is damaged.

Check whether the lead connecting the Hall element on the color wheel and the PCB board is in poor contact or disconnected.

Check whether the motor on the color wheel is damaged.

Check whether the related circuit of the motor drive board on the color wheel is damage.

7. Gobo1/2 Reset Error

Check whether the position of the gobo wheel1/2 where the magnet is installed falls off or is damaged.

Check whether there are obstacles in the gobo wheel1/2 operating range.

Check whether the Hall element on the gobo wheel1/2 is damaged.

Check whether the lead connecting the Hall element on the gobo wheel1/2 and the PCB board is in poor contact or disconnected.

Check whether the motor on the gobo wheel1/2 is damaged.

Check whether the related circuit of the motor drive board on the gobo wheel1/2 is damage.

8. R-Gobo1 Reset Error

Check whether the position of the gobo wheel1 where the magnet is installed falls off or is damaged.

Check whether there are obstacles in the gobo wheel1 operating range.

Check whether the Hall element on the gobo wheel1 is damaged.

Check whether the lead connecting the Hall element on the gobo wheel1 and the PCB board is in poor contact or disconnected.

Check whether the motor on the gobo wheel1 is damaged.

Check whether the related circuit of the motor drive board on the gobo wheel1 is damage.

9. Prism1/2 Reset Error

Check whether the position of the prism1/2 where the magnet is installed falls off or is damaged.

Check whether there are obstacles in the prism1/2 operating range.

Check whether the Hall element on the prism1/2 is damaged.

Check whether the lead connecting the Hall element on the prism1/2 and the PCB board is in poor

contact or disconnected.

Check whether the motor on the prism1/2 is damaged.

Check whether the related circuit of the motor drive board on the prism1/2 is damage.

10. R-Prism1/2 Reset Error

Check whether the position of the prism1/2 where the magnet is installed falls off or is damaged.

Check whether there are obstacles in the prism1/2 operating range.

Check whether the Hall element on the prism1/2 is damaged.

Check whether the lead connecting the Hall element on the prism1/2 and the PCB board is in poor contact or disconnected.

Check whether the motor on the prism1/2 is damaged.

Check whether the related circuit of the motor drive board on the prism1/2 is damage.

11. Focus Reset Error

Check whether the position of the focus where the magnet is installed falls off or is damaged.

Check whether there are obstacles in the focus operating range.

Check whether the Hall element on the focus is damaged.

Check whether the lead connecting the Hall element on the focus and the PCB board is in poor contact or disconnected.

Check whether the motor on the focus is damaged.

Check whether the related circuit of the motor drive board on the focus is damage.

12. Led Temp. Error

Check whether the temperature detecting board is normal.

Check whether the components of the temperature detecting board are damaged.

Check whether the lead on the temperature detecting board is installed in place or disconnected.

13. Led Temp. Too High

Check if the fan is working properly.

Check if the fan speed is normal.

Check if the ambient temperature is abnormal.

14. BaseFan1/2 Start Err

Check whether the fan is not running.

Check whether the fan leads are installed in place or disconnected.

Check whether the fan is damaged.

Check whether there are obstacles in the fan operating range.

15. BaseFan1/2 Stop Err

Check whether the fan circuit on the motherboard breaks down.

Check whether the component is damaged.

16. BaseFan1/2 Too Low

Check whether the fan is out of order.

Check whether there are obstacles in the fan operating range.

17. BaseFan1/2 Too High

Check whether the fan is out of order.

Check whether the fan circuit on the motherboard breaks down.

18. HeadFan1/2/3/4/5/6/7/8 Start Err

Check whether the fan is not running.

Check whether the fan leads are installed in place or disconnected.

Check whether the fan is damaged.

Check whether there are obstacles in the fan operating range.

19. HeadFan1/2/3/4/5/6/7/8 Stop Err

Check whether the fan circuit on the motherboard breaks down.

Check whether the component is damaged.

20. HeadFan1/2/3/4/5/6/7/8 Too Low

Check whether the fan is out of order.

Check whether there are obstacles in the fan operating range.

21. HeadFan1/2/3/4/5/6/7/8 Too High

Check whether the fan is out of order.

Check whether the fan circuit on the motherboard breaks down.

22. ArmFan1 Start Err

Check whether the fan is not running.

Check whether the fan leads are installed in place or disconnected.

Check whether the fan is damaged.

Check whether there are obstacles in the fan operating range.

23. ArmFan1 Stop Err

Check whether the fan circuit on the motherboard breaks down.

Check whether the component is damaged.

24. ArmFan1 Too Low

Check whether the fan is out of order.

Check whether there are obstacles in the fan operating range.

25. ArmFan1 Too High

Check whether the fan is out of order.

Check whether the fan circuit on the motherboard breaks down.

The position of each fan of the fixture:

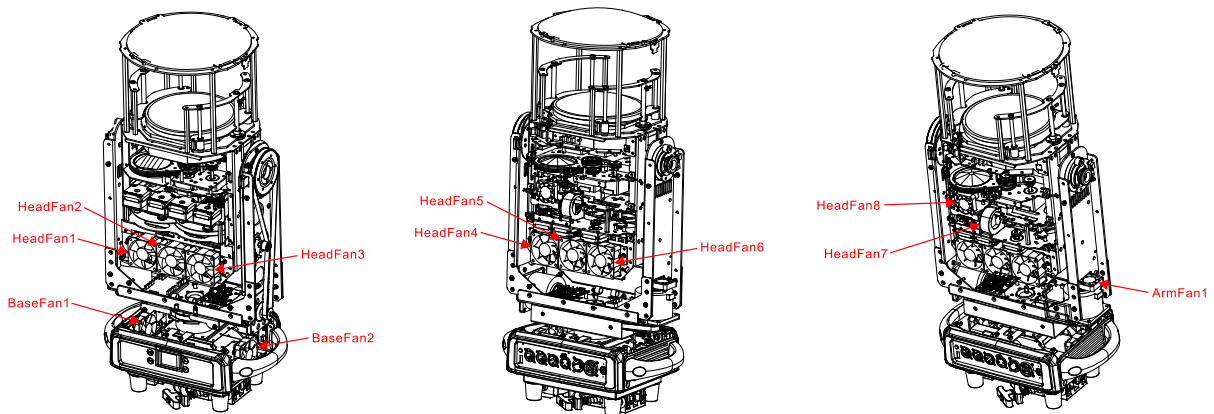

8. Troubleshooting

Following are a few common problems that may occur during operation. Here are some suggestions for troubleshooting:

A. The unit does not work, no light and the fan does not work

1. Check the connected power and main fuse.
2. Measure the voltage.
3. Check the power indicator to see whether it can be lit up or not.

B. Not responding to the DMX controller

1. Check whether the DMX connectors and the DMX cables are connected correctly.
2. Check whether the DMX address is correctly set.
3. If the intermittent DMX signal problem occurs, check whether the XLR socket and the signal cable are well connected.
4. Try it with another DMX controller.
5. Check whether the DMX cables run near or alongside to the high-voltage cables, which may damage or interfere with the signal circuit.

C. One of the channels is not working well

1. The stepper motor might be damaged or the cable connected to the PCB might be broken.
2. The motor's drive IC on the PCB might be out of condition.

9. Fixture Cleaning

It is absolutely essential that the fixture is kept clean to ensure the maximum light-output and allow the fixture to function reliably throughout its life. The fixture must be cleaned regularly to avoid dust, dirt and smoke-fluid residues building up on or within the fixture. The cleaning frequency depends on the application environment. Clean the fixture immediately if the dust enters it to avoid damage to the optical lens due to excessive dust.

- A soft lint-free cloth moistened with any good glass cleaning fluid is recommended, under no circumstances should solvents be used.
- Always dry the parts carefully.
- Clean the external optical lens at least every 20 days and the internal optical lens every 30 days.

Declaration of Conformity

We declare that our products (lighting equipments) comply with the following specification and bears CE mark in accordance with the provision of the Electromagnetic Compatibility (EMC) Directive 2014/30/EU.

EN 55032: 2015+A11:2020; EN IEC 61000-3-2: 2019;
EN 61000-3-3: 2013+A1: 2019; EN 55035: 2017+A11: 2020.

&

Harmonized Standard

EN 60598-1: 2015+A1: 2018; EN 60598-2-17: 2018;
EN 62493: 2015.

Safety of household and similar electrical appliances
Part 1: General requirements and tests

Certifications

cETLus Approved (Control #5000057)

Innovation, Quality, Performance